

## Space-Maker Pivoting Trellis, 4'

Double your raised bed space by growing up or out! The trellis is designed to fit into the one-inch aluminum corners of our 4' Cedar Raised Beds, Elevated Cedar Raised Beds, Elevated Cedar Planter Boxes and Elevated U-Gardens. The unique bracket system lets you adjust the trellis angle to customize it to your crop. Install it in the vertical position to support tall plants like tomatoes and peas. Or, install it at a 45° angle for spreading vines, like cucumbers.

### Parts Included

- 2 Short Brackets, left and right
- 2 Long Brackets, left and right
- 2 Threaded Knobs
- 1 Upper Panel
- 1 Lower Panel
- 4 Clips

### Assembly

**Step 1.** Place a Short Bracket over the threaded post of the Bottom Panel, as shown in Figure 1. Then, place a Long Bracket over the threads and cogs of the Short Bracket. Adjust the Long Bracket to the desired angle up to 45 degrees, as shown below.

**Step 2.** Be sure the cogs of the Short Bracket are completely seated in the Long Bracket. Twist the Threaded Knob onto the threaded post and hand tighten it firmly.

**Step 3.** Repeat Steps 1 and 2 to assemble the other side.

**Step 4.** Remove the Corner Caps from the two aluminum corners of your raised bed. Slide the Long Brackets into the aluminum corners until they are completely seated (Figure 2).

**Step 5.** Slide the Upper Panel onto the Lower Panel. Attach the panels together with the Clips, spacing the Clips evenly across the panels (Figure 3). Assembly is complete.

To change the angle of the trellis, remove the Threaded Knobs and separate the Long and Short Brackets. Adjust the angle, then reseat the Brackets and tighten the Threaded Knobs.

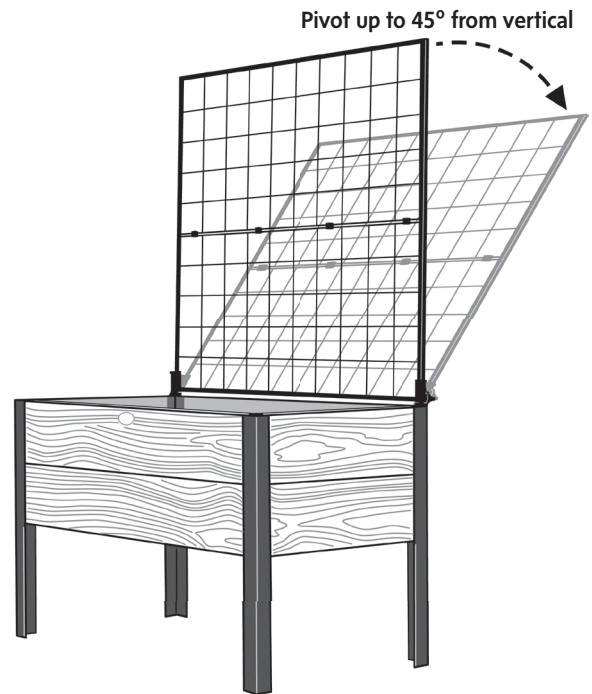

Figure 1

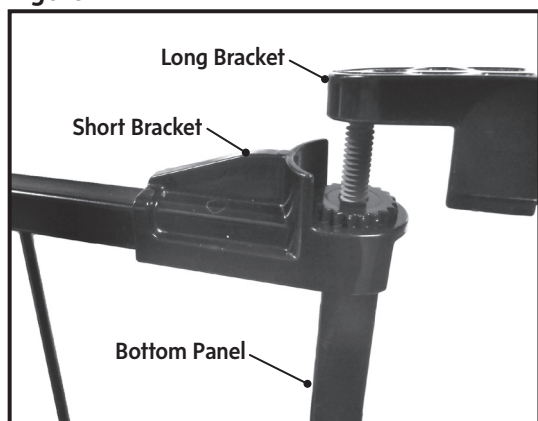

Figure 2

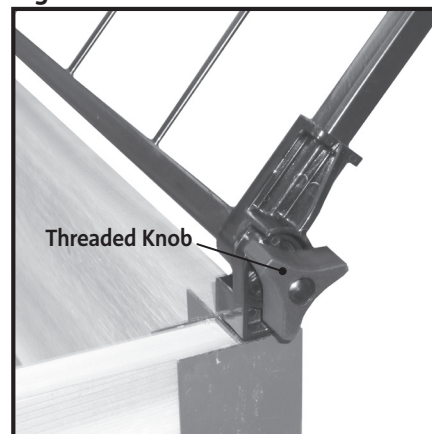

Figure 3

